

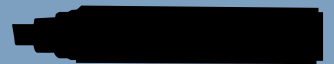

Science... is just science.
Until you make it improve the world.

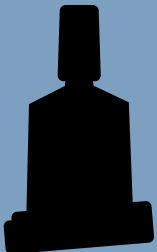
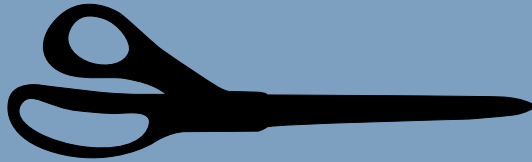
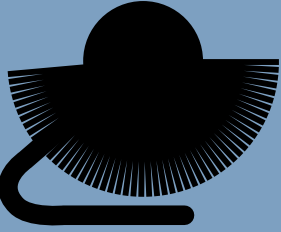
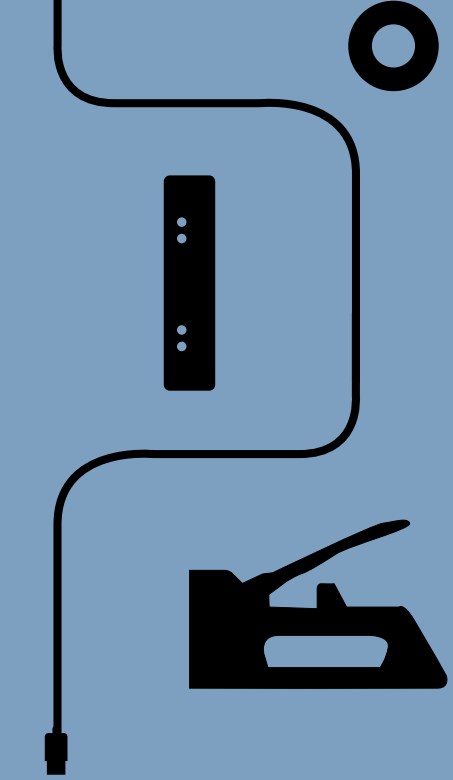
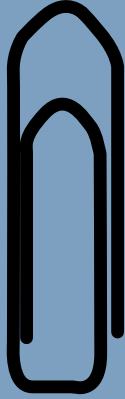
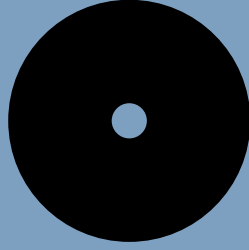
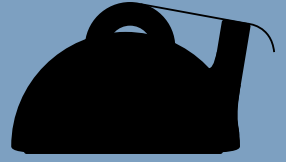

Girsberger Office Seating

Das Büro wandelt sich – Kommunikation, Kollaboration und Teamarbeit werden zunehmend wichtiger. Infolgedessen wird das Büro immer mehr zu einem Begegnungsort, der mit unterschiedlich eingerichteten Zonen verschiedene kommunikative Prozesse und Tätigkeiten unterstützt. Diese Entwicklung hat auch Auswirkungen auf die Büromöblierung. Der Bedarf an Stuhl- und Tischlösungen, welche Kommunikation und Kollaboration gezielt unterstützen, steigt. Ergänzend dazu wird aber auch weiterhin der komfortable und top-ergonomische Drehstuhl für die konzentrierte Einzelarbeit und Sacharbeit benötigt – und dafür ist Girsberger nach wie vor Spezialist.

Die beiden neuen Modellreihen Nava und Akio ermöglichen universelle Stuhl- und Tischlösungen, die für diverse Besprechungs- und Begegnungsbereiche im Büro eingesetzt werden können. Und die Neuauflage des Girsberger Atelierhockers von 1910 ist insbesondere für informelle Kommunikation und Teamarbeit geeignet. Es gibt ihn in einer normalen und einer hohen Sitzhöhe, so dass er auch an einem High Desk eingesetzt werden kann. Das Sofa Joline schliesslich ermöglicht besonders gemütliche Besprechungsbereiche. Es verfügt über eine normale Arbeitssitzhöhe, so dass gemeinsam an einem Tisch gearbeitet werden kann – aber mit dem Komfort eines Sofas. Darüber hinaus gibt es auch eine niedrige Ausführung für Warte- und Relaxbereiche im Büro.

The office is changing – communication, collaboration and teamwork are increasing in importance. As a result, the office is becoming more of a meeting place with differently equipped zones to support various communicative processes and activities. This trend is also having an effect on office furniture. The need for chair and table solutions that support communication and collaboration is rising. In addition, the comfortable, highly ergonomic swivel chair is still necessary for focused independent and skilled work – and Girsberger remains an expert in this area.

























The two new model series Nava and Akio enable universal chair and table solutions that can be used in a range of discussion and meeting areas in the office. And the relaunch of the Girsberger workshop stool from 1910 is particularly suited to informal communication and teamwork. It is available in both normal and high versions, meaning it can also be used at a high desk. Finally, the Joline sofa makes for extremely comfortable discussion areas. It has the usual height for working to enable people to work together at a table – but with the comfort of a sofa. There is also a lower version for waiting and relaxation areas in the office.



Linq Drehstuhl Swivel chair

Übersicht Office Seating Kollektion

Overview of Office Seating Collection

	S/P 10	S/P 11	S/P 14	S/P 15	S/P 18	S/P 22	S/P 23	S/P 26	S/P 27	S/P 30	S/P 31
											
Modell	Camiro	Camiro w&m	Diagon	Diagon Exec.	Reflex	Yanos	Kyra	Linq	Linq High Stool	Modell 111	Sway
Model	Design: Martin Ballendat	Design: Martin Ballendat	Design: Burkhard Vogtherr	Design: Burkhard Vogtherr	Design: Dieter Stierli	Design: Paul Brooks	Design: Paul Brooks	Design: Jonathan Prestwich	Design: Jonathan Prestwich	Design: Werksdesign 1910	Design: Burkhard Vogtherr
	Drehstuhl Freischwinger Swivel chair Cantilever chair	Drehstuhl Konferenz- drehstuhl Swivel chair Conference swivel chair	Drehstuhl Freischwinger Swivel chair Cantilever chair	Drehstuhl Freischwinger Swivel chair Cantilever chair	Drehstuhl Freischwinger Swivel chair Cantilever chair	Drehstuhl Freischwinger Vierbeinstuhl Swivel chair Cantilever chair Four-legged chair	Drehstuhl Freischwinger Vierbeinstuhl Swivel chair Cantilever chair Four-legged chair	Drehstuhl Konferenz- drehstuhl Swivel chair Conference swivel chair	High Stool Drehstuhl hoch High stool High swivel chair	Atelierhocker hoch Workshop stool Workshop stool tall	Stehsitz Hocker Standing seat Stool
Varianten											
Versions											

S/P 34 S/P 39 S/P 40 S/P 42 S/P 43 S/P 46 S/P 47 S/P 50 S/P 51 S/P 52 S/P 53



Nava Alambre G 125 Jack Modell 1600 Joline Work Joline Lounge Pablo Pablo Modular Linked Otto

Design: Tom Deacon Design: Alfredo Häberli Design: Mathias Seiler Design: Burkhard Vogtherr Design: Werksdesign 1961 Design: Mathias Seiler Design: Mathias Seiler Design: Orlandini Design Design: Orlandini Design Design: Carlos Tiscar Design: Carlos Tiscar

Kufenstuhl
Vierbeinstuhl
Vierbeinstuhl
mit Armlehnen
Vierbeinstuhl Holz
Kufenstuhl hoch
Skid-frame chair
Four-legged chair
Four-legged chair
with armrests
Four-legged chair
wood
High skid-frame
chair

Kufenstuhl
Skid-frame chair

Drehstuhl
Konferenz-
drehstuhl
Swivel chair
Conference
swivel chair

Drehstuhl
Vierbeinstuhl
Loungechair
Swivel chair
Four-legged chair
Lounge chair

Sessel
Hocker
Beistelltisch
Armchair
Stool
Side table

Zweisitzer
Dreisitzer
Viersitzer
Two-seater
Three-seater
Four-seater

Zweisitzer
Dreisitzer
Viersitzer
Beistelltisch
Two-seater
Three-seater
Four-seater
Side table

Sessel
Zweisitzer
Hocker
Beistelltisch
Arbeits-tisch
Armchair
Two-seater
Stool
Side table
Working table

Sitzmodule
Seat modules

Wandelemente
Tisch
Garderobe
Wall elements
Table
Coat rack

Sessel
Hocker
Verbindungstisch
Beistelltisch
Arbeits-tisch
Armchair
Stool
Connecting table
Side table
Working table





Camiro Drehstuhl | Swivel chair

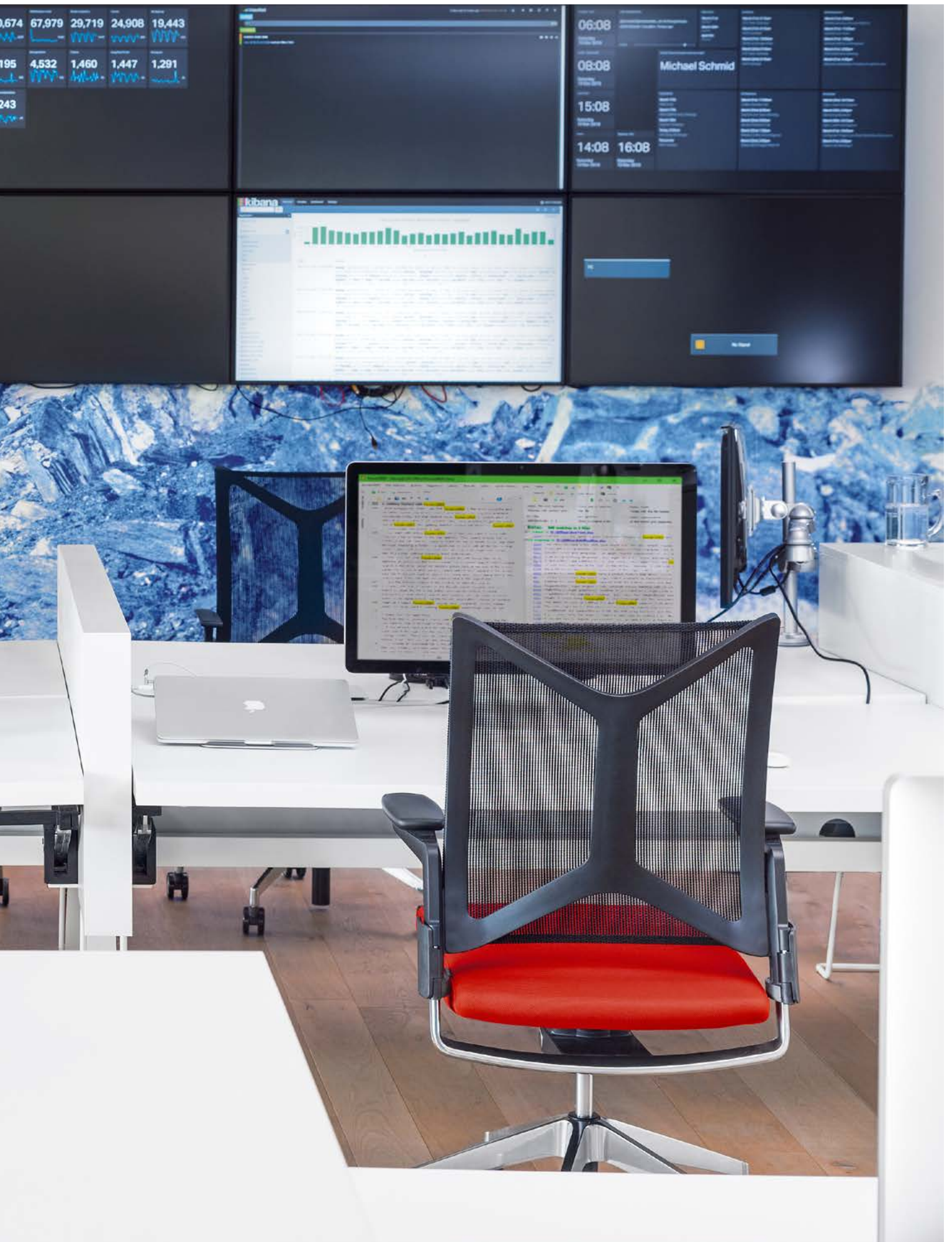



Camiro	Design	Rücken / Backrest	Bezug / Covering	Versionen / Versions
	Martin Ballendat	Netz, Polster Mesh, upholstery	Textil, Leder Textile, leather	Drehstuhl, Freischwinger Swivel chair, cantilever chair



Design	Rücken / Backrest	Bezug / Covering	Versionen / Versions	Camiro work&meet
Martin Ballendat	Netz, Polster Mesh, upholstery	Textil, Leder Textile, leather	Drehstuhl, Konferenzdrehstuhl Swivel chair, conference swivel chair	



Camiro work&meet Konferenzdrehstuhl Conference swivel chair



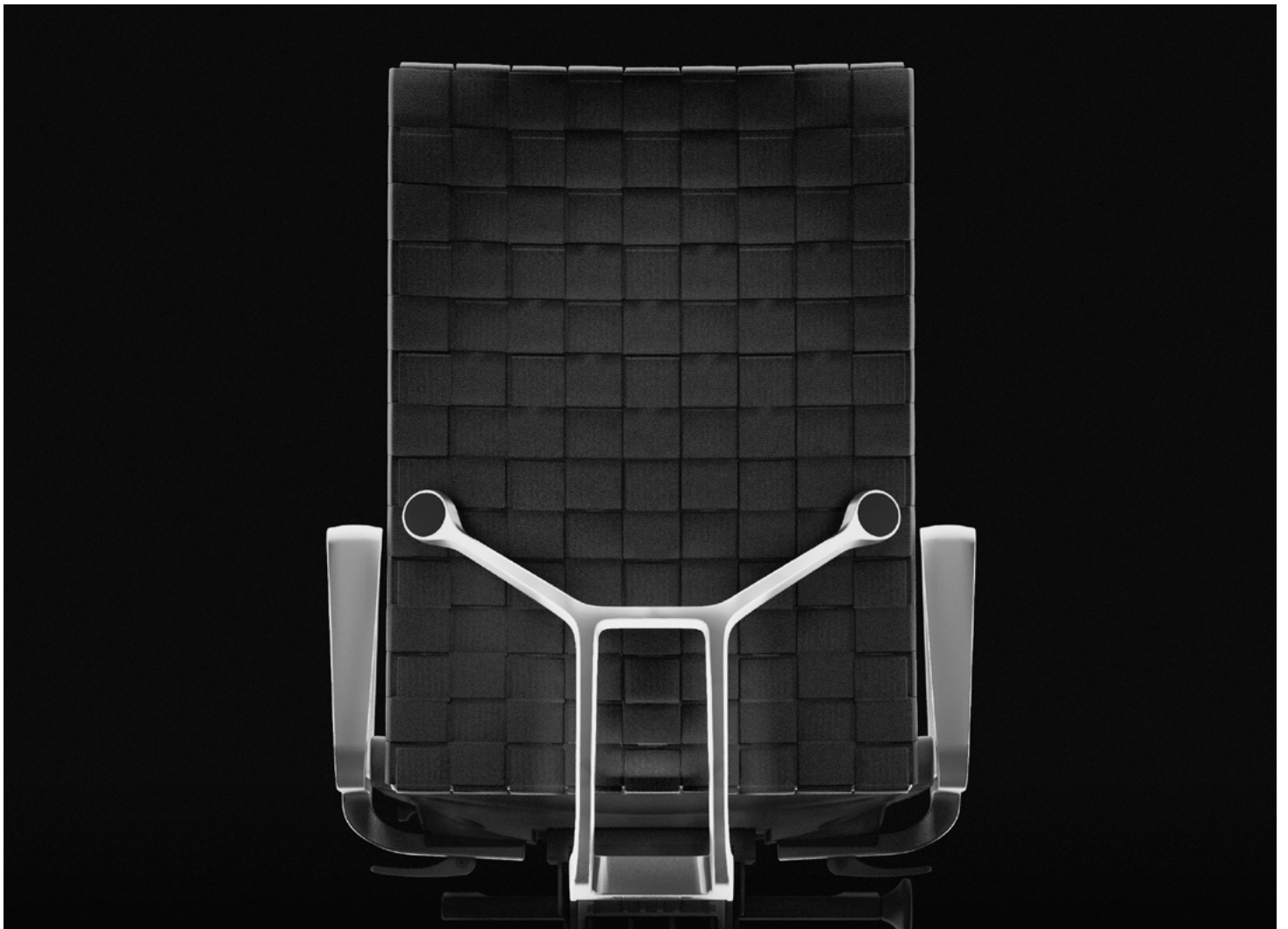

Diagon	Design	Rücken / Backrest	Bezug / Covering	Versionen / Versions
	Burkhard Vogtherr	Netz, Bandgeflecht, Polster Mesh, woven bands, upholstery	Netz, Textil, Leder Mesh, textile, leather	Drehstuhl, Freischwinger Swivel chair, cantilever chair



Design	Rücken / Backrest	Bezug / Covering	Versionen / Versions	Diagon Executive
Burkhard Vogtherr	Polster Upholstery	Leder Leather	Drehstuhl, Freischwinger Swivel chair, cantilever chair	



Diagon Executive Freischwinger Cantilever chair



Drehstuhl Swivel chair **Diagon Executive**



Reflex	Design	Rücken / Backrest	Bezug / Covering	Versionen / Versions
	Dieter Stierli	Netz, Polster Mesh, upholstery	Textil, Leder Textile, leather	Drehstuhl, Freischwinger Connexion Swivel chair, cantilever chair Connexion



Design

Rücken / Backrest

Bezug / Covering

Versionen / Versions

Connexion

Dieter
Stierli

Netz, Polster
Mesh, upholstery

Textil, Leder
Textile, leather

Freischwinger
Cantilever chair



Reflex Drehstuhl Swivel chair



Drehstuhl Swivel chair **Yanos**



Yanos	Design	Rücken / Backrest	Bezug / Covering	Versionen / Versions
Paul Brooks	Netz, Polster Mesh, upholstery	Netz, Polster Mesh, upholstery	Textil, Leder Textile, leather	Drehstuhl, Freischwinger, Vierbeinstuhl Swivel chair, cantilever chair, four-legged chair



Design	Rücken / Backrest	Bezug / Covering	Versionen / Versions
Paul Brooks	Polster Upholstery	Textil, Leder Textile, leather	Drehstuhl, Freischwinger Yanos, Vierbeinstuhl Yanos Swivel chair, cantilever chair Yanos, four-legged chair Yanos



Linq Konferenzdrehstuhl Conference swivel chair



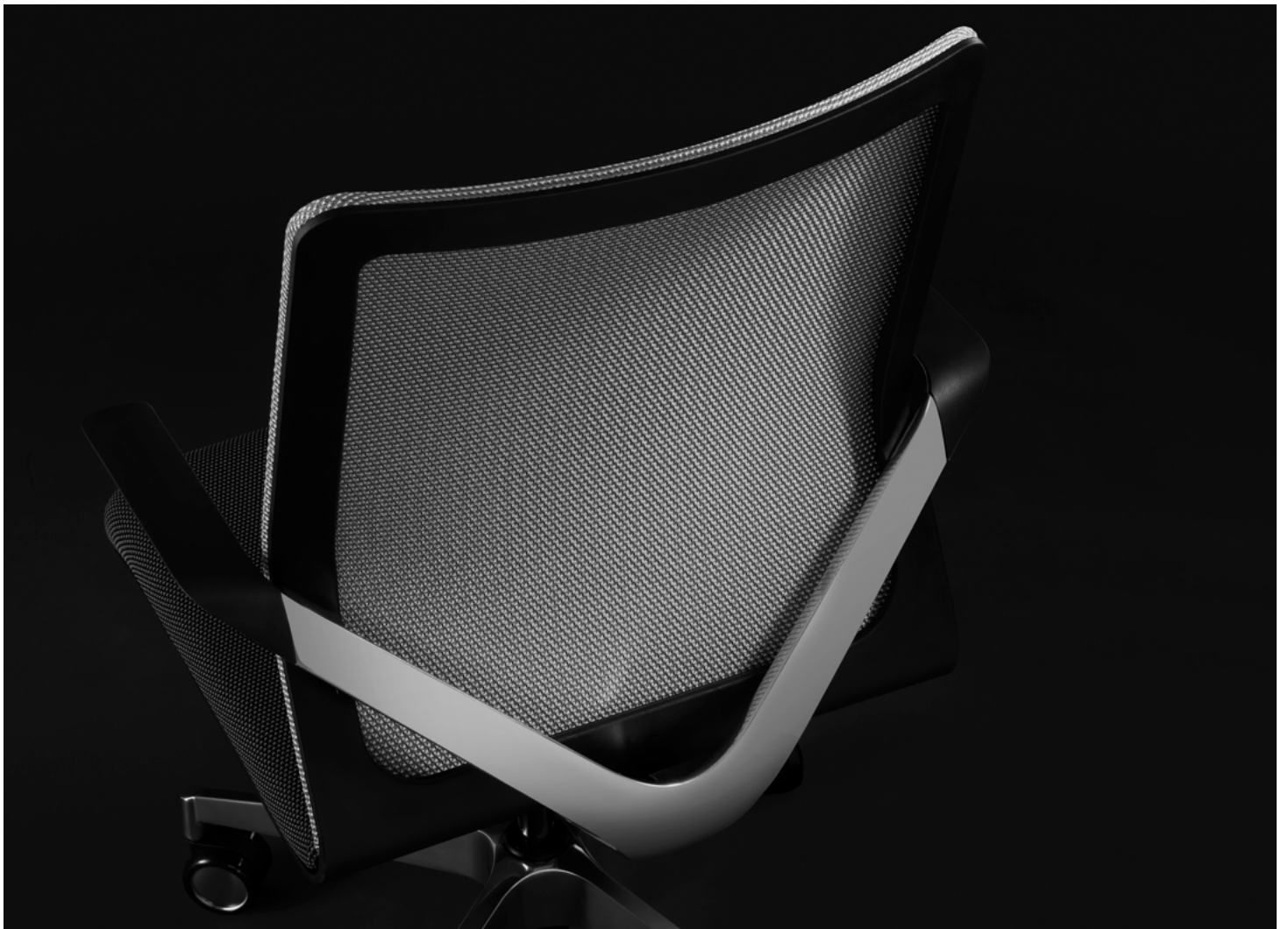

Linq

Design

Rücken / Backrest

Bezug / Covering

Versionen / Versions

Jonathan
Prestwich

Netz, Polster
Mesh, upholstery

Netz, Textil, Leder
Mesh, textile, leather

Drehstuhl, Konferenzdrehstuhl
Swivel chair, conference swivel chair



Design	Bezug / Covering	Versionen / Versions	Linq High Stool
Jonathan Prestwich	Netz Mesh	Drehstuhl hoch mit Fussbügel oder Fussring High swivel chair, with footrest or foot ring	

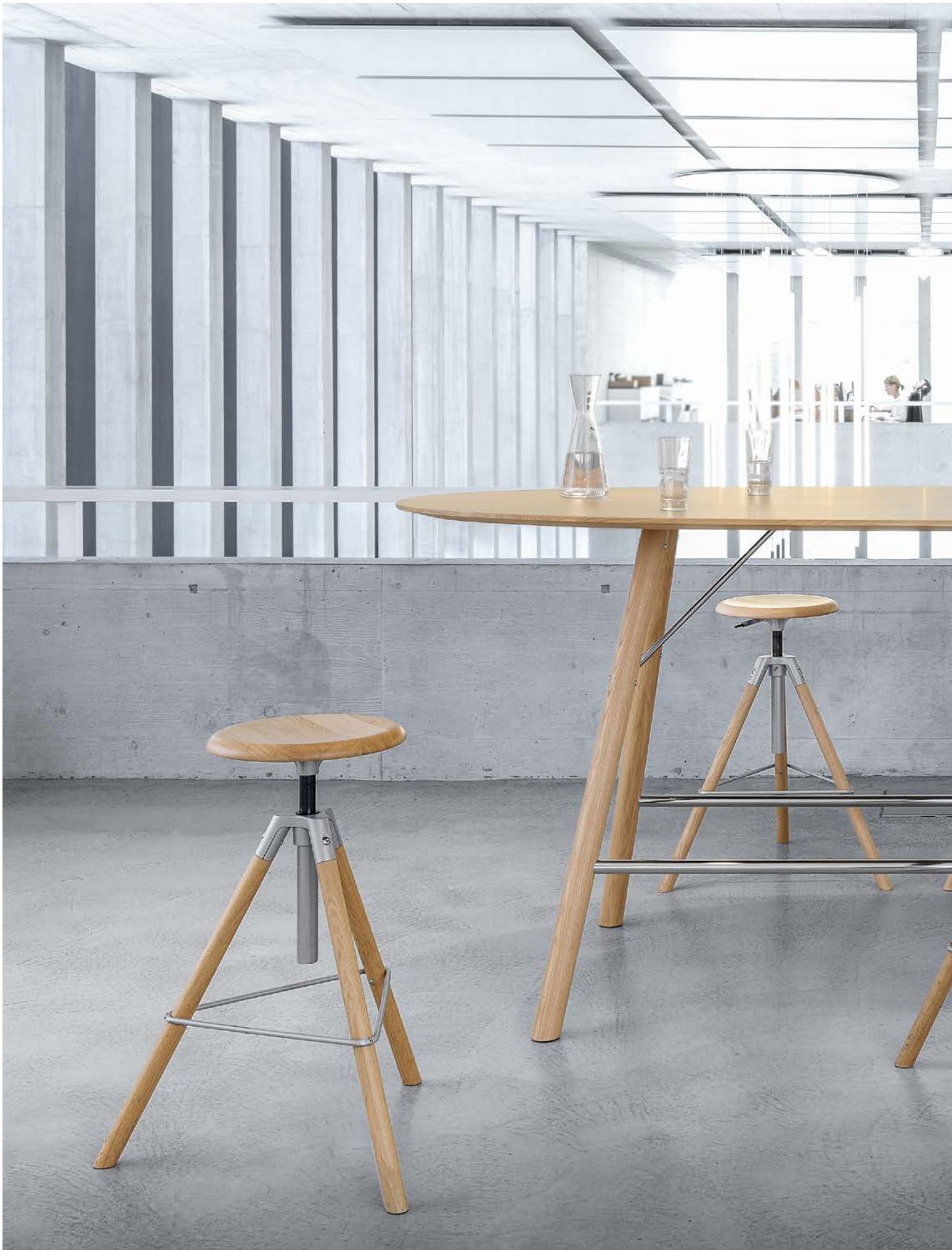

Modell 111/112 Atelierhocker Workshop stool



Hochtisch High table **Akio**



Modell 111/112

Design

Girsberger Werksdesign 1910

Sitz / Seat

Holz, Polster
Wood, upholstery

Bezug / Covering

Textil, Leder
Textile, leather

Versionen / Versions

Hocker, Hocker hoch, höhenverstellbar
Stool, stool tall, height adjustable



Design	Bezug / Covering	Versionen / Versions	Sway
Burkhard Vogtherr	Netz Mesh	Stehsitz höhenverstellbar, Hocker Standing seat height adjustable, stool	



Nava Stuhl Chair



Tisch Table **Akio**



Nava	Design Tom Deacon	Schale / Shell Kunststoffschale ohne/mit Sitzpolster, Vollpolster Linear/Kontur Plastic shell without/with seat upholstery, fully upholstered Linear/Kontur	Bezug / Covering Textil, Leder Textile, leather
-------------	----------------------	---	---



Versionen / Versions

Nava

Vierbeinstuhl, Vierbeinstuhl mit Armlehnen, Kufenstuhl, Kufenstuhl hoch, Vierbeinstuhl Holz
Four-legged chair, four-legged chair with armrests, skid-frame chair, high skid-frame chair, four-legged chair wood



Nava / Akio Stuhl Chair / Tisch Table



Sessel, Beistelltisch Armchair, side table **Modell 1600**

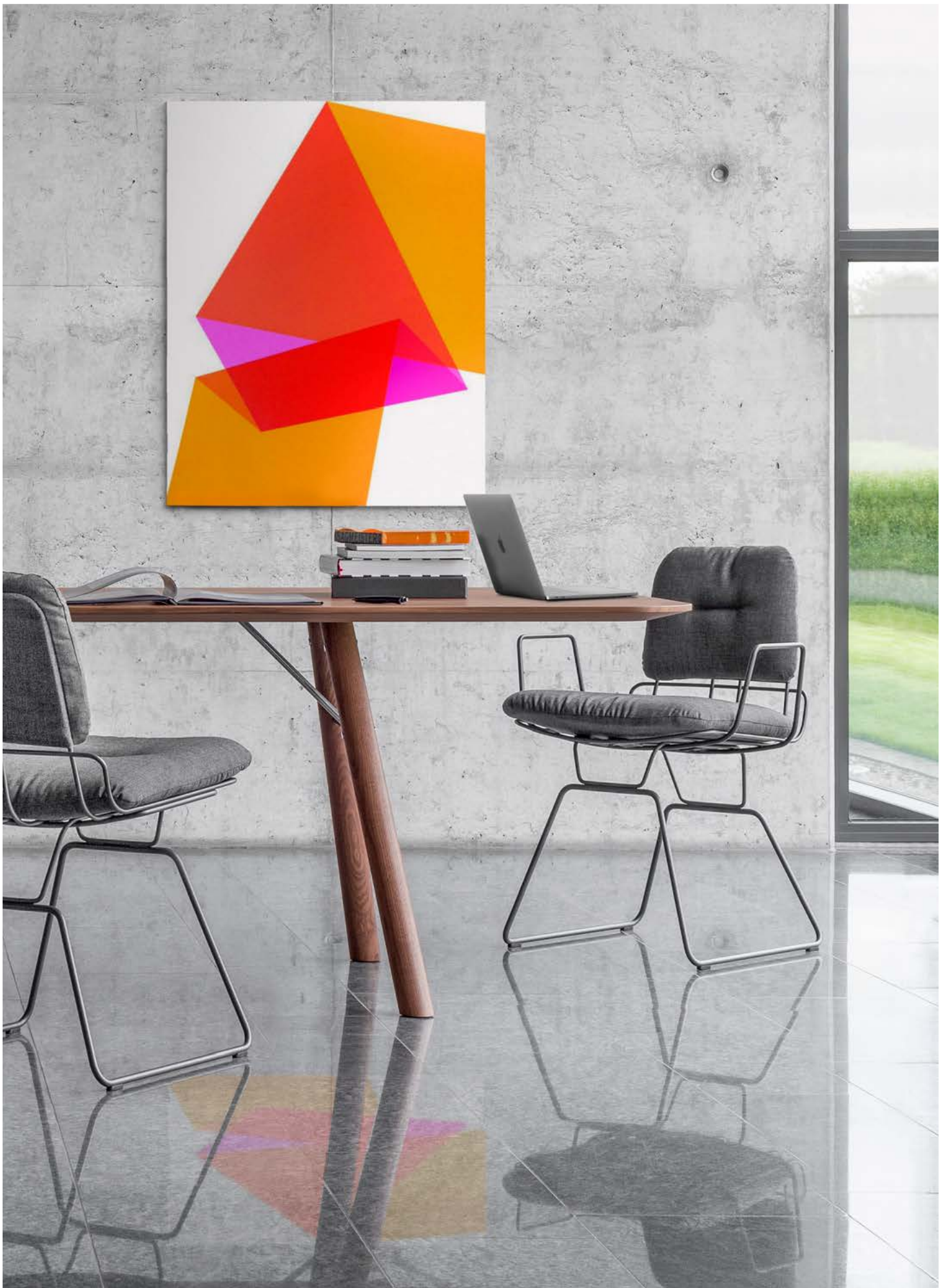

Alambre Stuhl Chair

Tisch Table **Akio**



Design

Schale / Shell

Bezug / Covering

Versionen / Versions

Alambre

Alfredo Häberli

Sitz- und Lehnenkissen
Seat and backrest cushions

Textil, Leder
Textile, leather

Kufenstuhl, Kufenstuhl mit Armlehnen
Skid-frame chair, skid-frame chair with armrests



G 125

Design

Sitz / Seat

Bezug / Covering

Versionen / Versions

Mathias
Seiler

Netz, Polster
Mesh, upholstery

Textil, Leder
Textile, leather

Drehstuhl mit Viersternfuss Holz, Fünfsternfuss Stahl
Swivel chair with four-prong base in wood, five-prong base in steel



Drehstuhl Swivel chair **G 125**



Jack

Design

Schale / Shell

Bezug / Covering

Versionen / Versions

Burkhard
Vogtherr

Polster
Upholstery

Textil, Leder
Textile, leather

Drehstuhl, Vierbeinstuhl, Loungechair
Swivel chair, four-legged chair, lounge chair



Design

Schale / Shell

Bezug / Covering

Versionen / Versions

Modell 1600

Werksdesign 1961

Polster
Upholstery

Textil, Leder
Textile, leather

Sessel, Hocker, Beistelltisch
Armchair, stool, side table

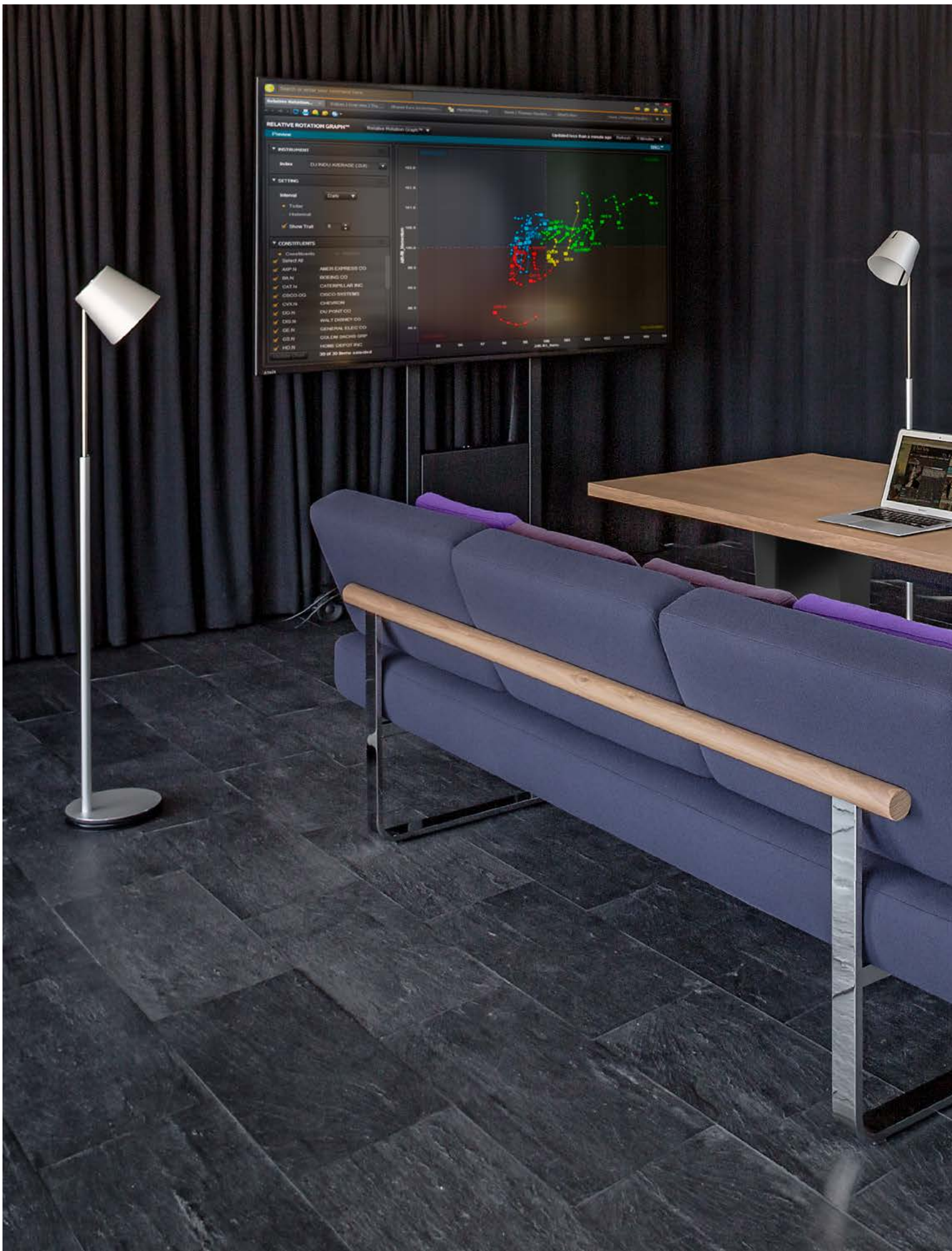

Joline Sofa Sofa



Tisch Table **Onda**



Joline Work

Design

Sitz, Rücken / Seat, backrest

Bezug / Covering

Versionen / Versions

Mathias
Seiler

Polster
Upholstery

Textil, Leder
Textile, leather

Zweisitzer, Dreisitzer, Viersitzer
Two-seater, three-seater, four-seater



Design	Sitz, Rücken / Seat, backrest	Bezug / Covering	Versionen / Versions	Joline Lounge
Mathias Seiler	Polster Upholstery	Textil, Leder Textile, leather	Zweisitzer, Dreisitzer, Viersitzer, Beistelltisch Two-seater, three-seater, four-seater, side table	



Pablo Modular Sitzmodule Seat modules

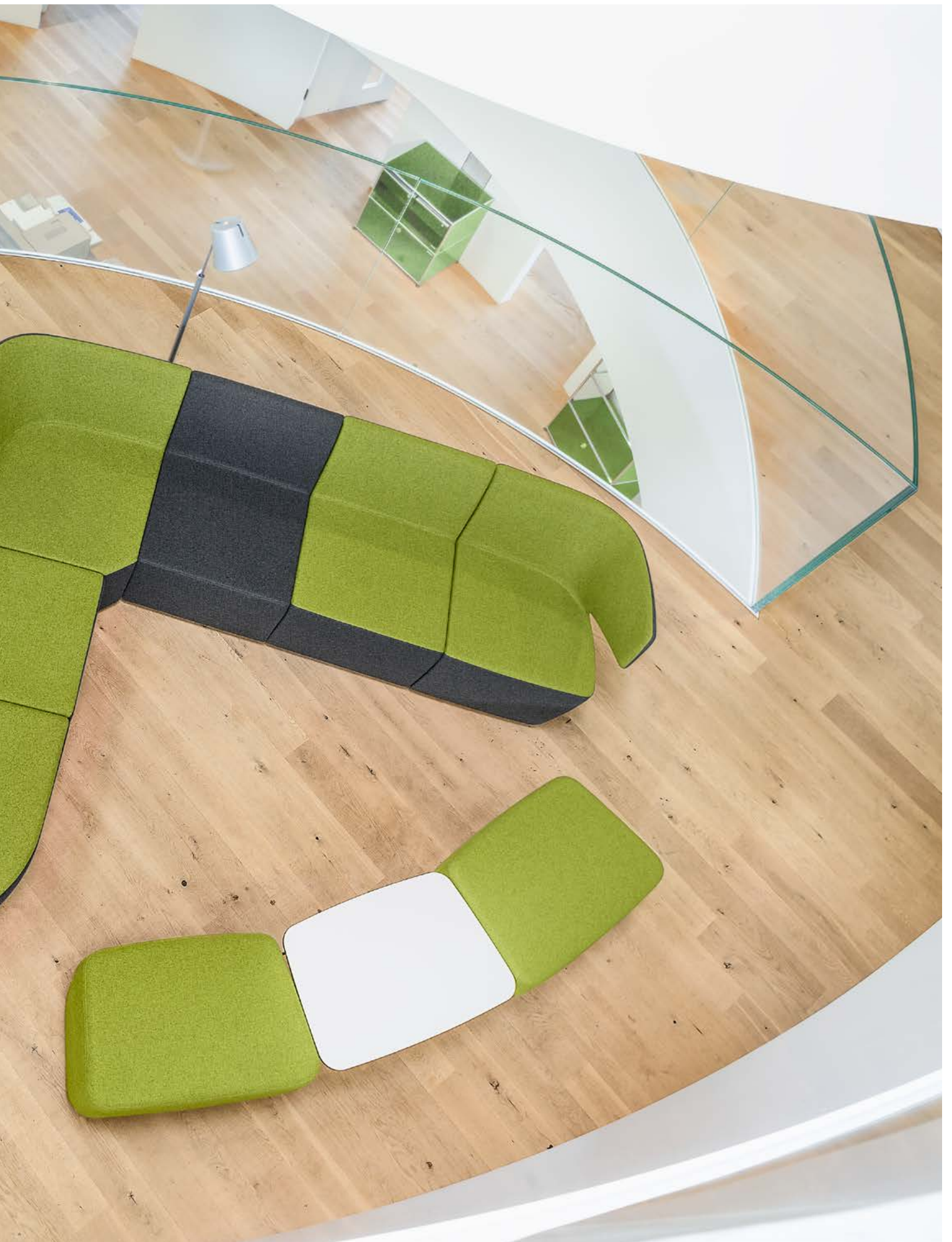

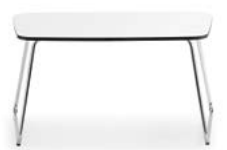

Pablo

Design

Schale / Shell

Bezug / Covering

Versionen / Versions

Orlandini
Design

Polster
Upholstery

Textil, Leder
Textile, leather

Sessel, Zweisitzer, Hocker, Beistelltisch
Armchair, two-seater, stool, side table



Design	Schale / Shell	Bezug / Covering	Versionen / Versions	Pablo Modular
Orlandini Design	Polster Upholstery	Textil, Leder Textile, leather	Abschlussmodule, Eckmodule, Zwischenmodul End modules, corner modules, middle module	



Linked	Design	Füllmaterial / Filling material	Bezug / Covering	Versionen / Versions
	Carlos Tísicar	Weichfaserplatte, Akustikplatte Soft fibre board, acoustic panel	Netz, Stoff Mesh, textile	Wandelemente, Tisch, Garderobe Wall elements, table, coat rack



Design	Schale / Shell	Bezug / Covering	Versionen / Versions
Carlos Tiscar	Polster Upholstery	Textil, Leder Textile, leather	Sessel, Hocker, Verbindungstisch, Beistelltisch, Arbeitstisch Armchair, stool, connecting table, side table, working table

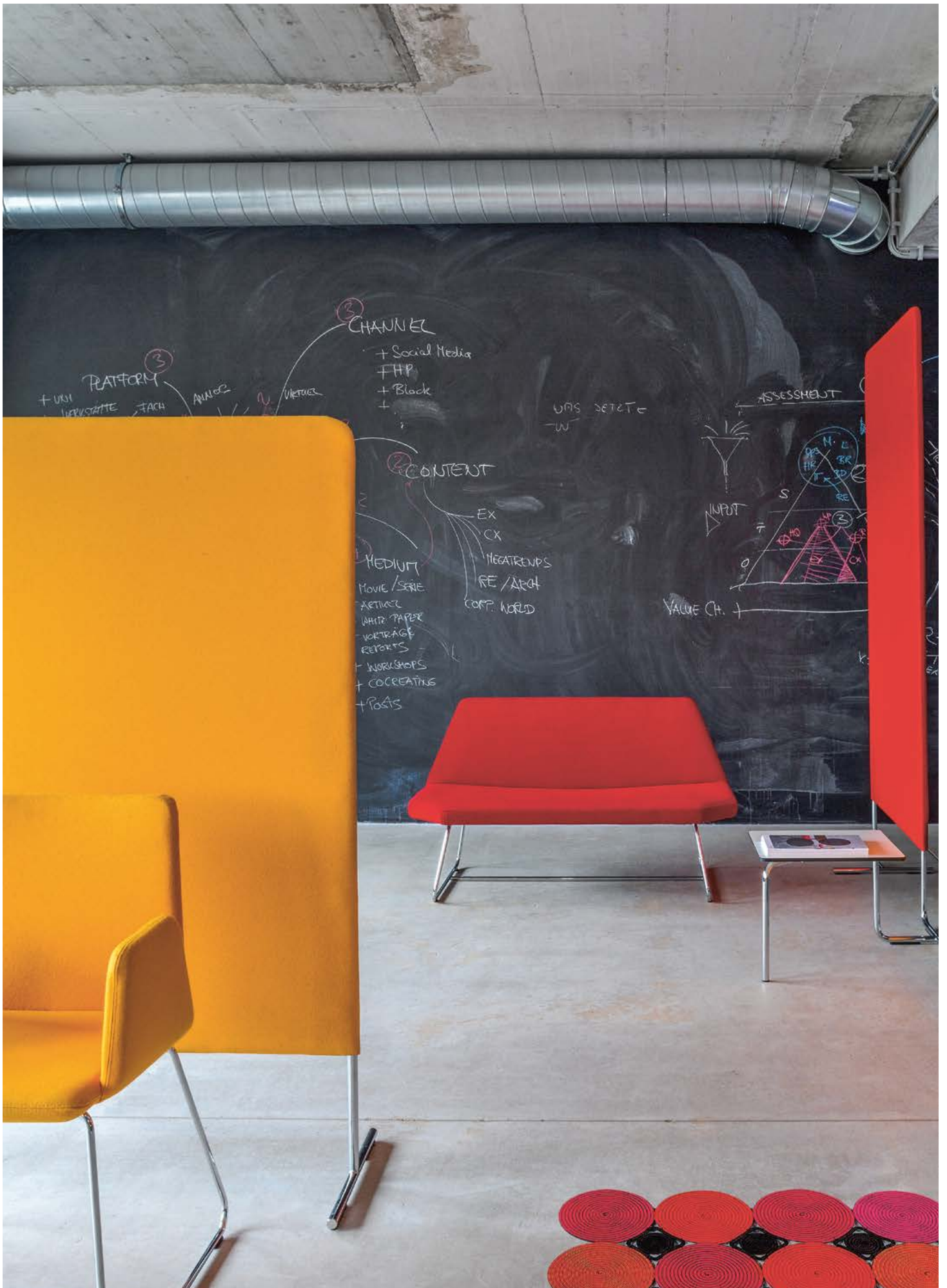

Linked Wandelement Wall element

Sessel Armchair Otto

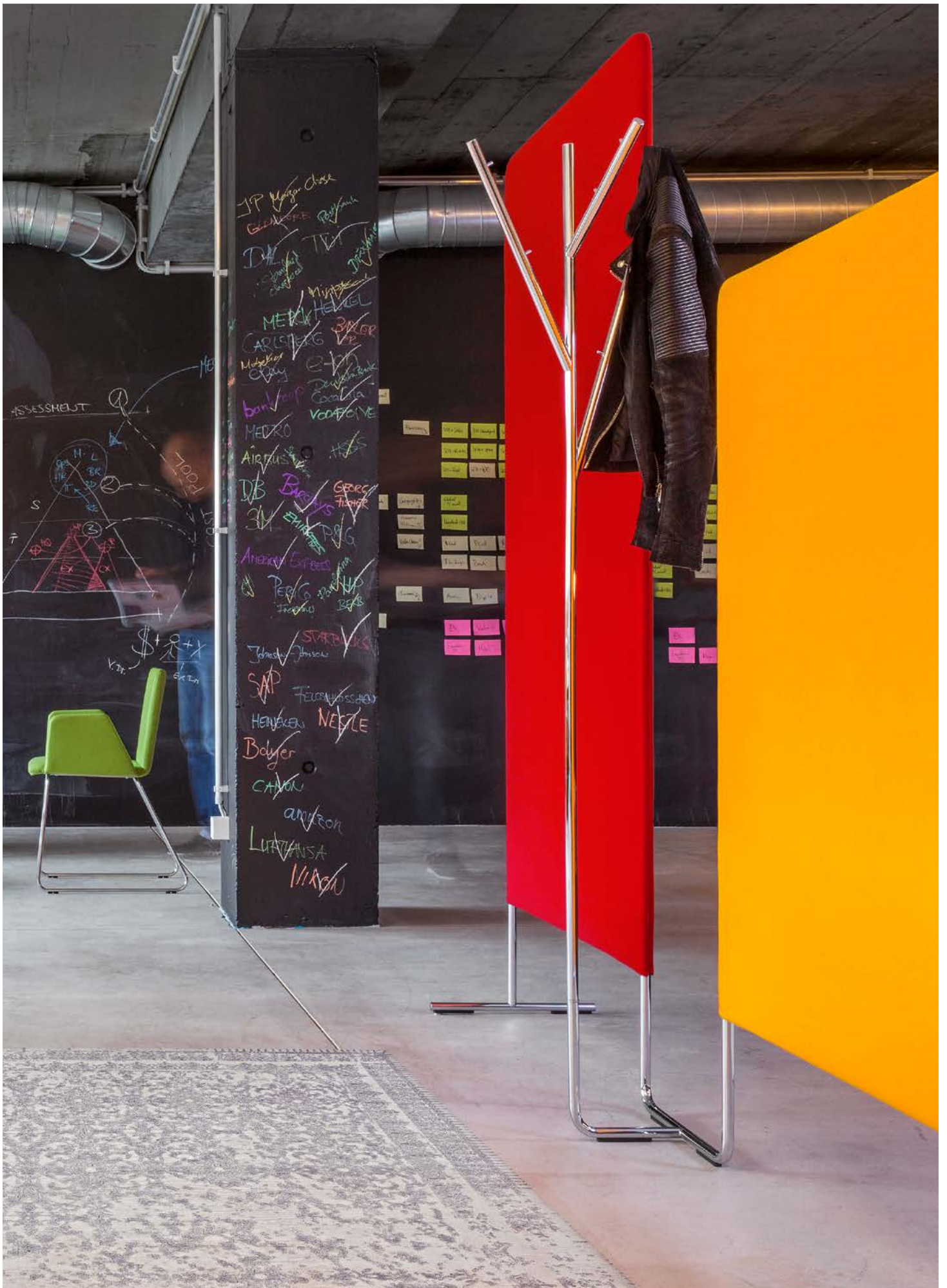

Pepe Stuhl Chair

Wandelement Wall element **Linked**

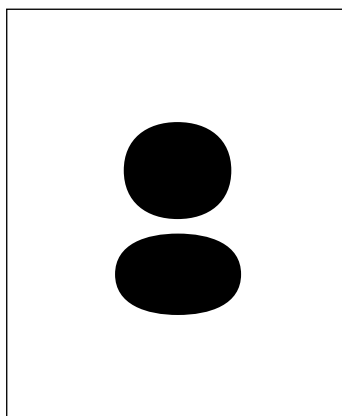

Girsberger Grundsätze

Girsberger ist ein Familienunternehmen. Als solches spiegelt es die Haltung und Überzeugung der Familie Girsberger wider.

Einen Grundsatz hat Michael Girsberger vor einigen Jahren so formuliert:

„Grössten Wert legen wir darauf, möglichst immer die richtige Balance zwischen ökonomischem Erfolg, sozialer Orientierung und ökologischer Verantwortung zu finden.“

Wer Girsberger kennt, weiss, dass diese Denkweise gelebt wird - täglich und in vielfältiger Beziehung. Sie zeigt sich beispielsweise darin, dass wir nur besonders umweltfreundliche und energieeffiziente Firmenfahrzeuge einsetzen.

www.girsberger.com/de/company/werte/grundsätze

Girsberger's principles

Girsberger is a family business. As such, it reflects the attitudes and convictions of the Girsberger family.

Several years ago, Michael Girsberger formulated one of the company's principles as follows: "We place the utmost importance on striking, wherever possible, the correct balance between financial success, social focus and ecological responsibility."

Anyone familiar with Girsberger will know that this approach is lived out every day and in many different ways. It is seen, for example, in the fact that we use only eco-friendly and energy-efficient company vehicles.

www.girsberger.com/en/company/values/principles

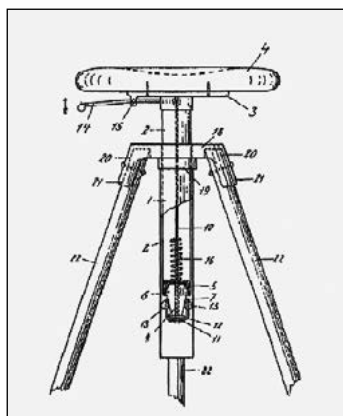

Ohne Tradition kein Fortschritt

Seit 1889, seit der Gründung der Drechslerei Heinrich Girsberger in Zürich, ist unser Name eng mit der Entwicklungsgeschichte des Sitzens verknüpft. Mit Stolz blicken wir auf eine lange Tradition zurück. Und was mit dem ersten Patent, dem Drehstuhl Typ 111, begann, war die Basis für viele nachfolgende Entwicklungen. Der Leitgedanke: Funktionalität mit hohem praktischem Nutzen, präzise Fertigung in handwerklicher Tradition sowie Materialehrlichkeit und Beständigkeit. Diese Eckpunkte bestehen bis heute und prägen jedes unserer Produkte, auch wenn sich vieles im Laufe der Zeit verändert hat.

Unsere Herkunft ist eine gute Basis für die Zukunft. Unser Anspruch, immer wieder neue Wege zu suchen, Bestehendes zu hinterfragen und nichts unbeachtet zu lassen, um das Bessere zu finden, hat Girsberger zu einem geachteten Unternehmen der Branche gemacht.

www.girsberger.com/de/company/history

No progress without tradition

Since 1889, when Heinrich Girsberger set up a woodworking shop in Zurich, our name has been closely associated with the history of seating. We can look back with pride at a long tradition. And what began with the first patent, the Type 111 swivel chair, became the basis for many subsequent developments. The guiding principles throughout: functionality and practicality, precise manufacture in the tradition of manual craftsmanship, authenticity of materials and durability.

These cornerstones remain in place to this day and characterize every one of our products, even if much has changed over time.

Our origins form a good basis for the future. Our determination always to seek new ways of doing things, question existing practices and leave no stone unturned in the quest to better our products has made Girsberger a highly respected company in the sector.

www.girsberger.com/en/company/history



Unsere soziale Verantwortung

Corporate Social Responsibility ist zu einem Schlagwort geworden. Immer mehr wird uns allen bewusst, dass die Gewährleistung sozialer Gerechtigkeit und die Schonung von Ressourcen die wichtigsten Herausforderungen für zukünftiges Wirtschaften sein werden. Die unternehmerische Verantwortung gegenüber der Gesellschaft war schon immer zentraler Teil der Firmenphilosophie von Girsberger. Inzwischen wollen aber auch unsere Kunden wissen: Unter welchen (fairen) Voraussetzungen werden die Produkte hergestellt? Welchen Einfluss hat die Produktion auf die Umwelt? Wie werden die eingesetzten Materialien entsorgt bzw. wiederverwendet?

Wir können darauf Antworten geben: Während andere Hersteller in Fernost produzieren lassen, fertigen wir nach wie vor in der Schweiz und in Deutschland. Komponenten, die wir nicht selbst herstellen, beziehen wir zu über 90% von Lieferanten, die im Umkreis von 800 km um unsere Werke angesiedelt sind. Damit stellen wir sicher, dass unsere Produkte sozial und ökologisch verträglich hergestellt und Ihren und unseren Ansprüchen an Qualität und Nachhaltigkeit gerecht werden.

[Download „Geschäftsbericht zur Nachhaltigkeit“ www.girsberger.com](http://www.girsberger.com)

Our social responsibility

Corporate social responsibility has become a buzz phrase. We are all becoming increasingly aware that ensuring social fairness and conserving resources are going to be the most important challenges for future business. Responsibility towards society has always been a core part of Girsberger's corporate philosophy. Now, however, our customers too have further questions. Under what conditions are the products made and are they fair? What impact does the production process have on the environment? How are the materials used disposed of or recycled? We have answers to these questions: while other manufacturers have their products made in the Far East, we continue to produce ours in Switzerland and Germany. Over 90% of all components that we do not produce ourselves are bought from suppliers based within a circumference of 800 km of our production sites. We thus ensure that our products are made in a socially and ecologically compatible way, and that they meet your expectations of quality and sustainability.

[Download our Sustainability Report www.girsberger.com](http://www.girsberger.com)



Nachhaltigkeit

Alle reden heute von Nachhaltigkeit. Wir tun es in der Regel nicht, weil wir in Bezug auf Ökologie und Qualität schon immer hohe Maßstäbe an unser Handeln gelegt haben. Selbstverständlich ist uns beispielsweise, dass wir Stühle herstellen, die aufgrund ihrer hohen Qualität auf eine lange Nutzungsdauer ausgelegt sind. Denn was lange hält und funktioniert, muss nicht ersetzt werden und schont Ressourcen. Selbstverständlich ist uns auch, dass Girsberger Stühle recyclinggerecht konstruiert werden und fast vollständig aus Werkstoffen bestehen, die wiederverwertet werden können. Darüber hinaus unterhalten wir seit 2007 ein zertifiziertes Umweltmanagementsystem nach EN ISO 14001, das uns verpflichtet, unsere Umwelleistung kontinuierlich zu verbessern. Es regelt die Verpflichtungen gegenüber unseren Kunden wie auch gegenüber unseren Lieferanten, die ebenfalls auf ihr Umweltverhalten geprüft werden.

[Download „Geschäftsbericht zur Nachhaltigkeit“ www.girsberger.com](#)

Sustainability

Everyone is talking about sustainability these days. We generally do not, as we have always set high standards in the way we operate in relation to ecology and quality. For instance, it is only natural to us to produce high-quality chairs that are designed to last. After all, what lasts and keeps working for a long time does not have to be replaced and thus conserves resources. It is also second nature that Girsberger chairs are designed with recycling in mind, and consist almost entirely of materials that can be used again. Since 2007, we have also operated an environmental management system certified to EN ISO 14001 standard, which obliges us to continually improve our environmental performance. The system governs our obligations towards both our customers and suppliers, who are also checked to ensure they operate in an environmentally compatible way.

[Download our Sustainability Report www.girsberger.com](#)

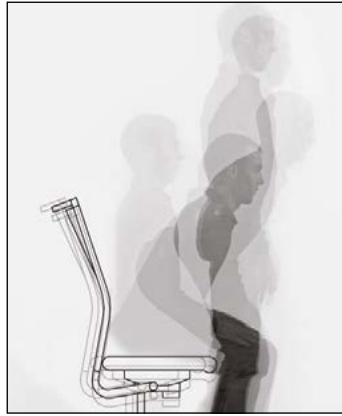

Es geht ums Sitzen!

Ob im Büro oder privat zu Hause, immer mehr Menschen arbeiten immer länger im Sitzen. Der Trend besteht schon lange, wurde aber durch die Arbeit am Computer noch verstärkt. Für uns Anlass, besonders gründlich über alle Aspekte des Sitzens nachzudenken. Vielleicht gelingt es uns deshalb immer wieder, neuartige Lösungen zu finden, die sich in zahlreichen Patentanmeldungen widerspiegeln. In der Produktentwicklung verwenden wir viel Zeit für die genaue Beobachtung und Auseinandersetzung mit dem Lebensraum Büro. Denn der ständige Wandel der Arbeitsweisen sowie der Fortschritt der Kommunikationstechnologien erfordern laufend neuartige Sitzlösungen. Darüber hinaus arbeiten wir interdisziplinär mit Spezialisten und Wissenschaftlern zusammen, um immer den neuesten Stand ergonomischer Erkenntnisse in unsere Überlegungen einzubeziehen.

[Download „Gesundes Sitzen“ www.girsberger.com](#)

It's all about sitting!

Whether in the office or at home, more and more people are spending an increasing amount of time sitting. This trend has existed for a long time but has been made even more pronounced by working with computers. For us at Girsberger, this is a good reason to reflect particularly thoroughly on all aspects of sitting. And perhaps that is why we repeatedly succeed in finding innovative solutions that are reflected in numerous patent registrations. When developing products, we take plenty of time to closely observe the way people use their office space, as the constant change in working methods and the advance of communication technologies continually call for novel seating solutions. Above and beyond this, we also collaborate with specialists and academics from various disciplines, enabling us to consistently incorporate the latest ergonomic findings into our work.

[Download our Healthy Sitting guide www.girsberger.com](#)



Individuelle Fertigung

Bürostühle fertigen wir seit einem halben Jahrhundert in Endingen am Kaiserstuhl. Und dies aus gutem Grund. Denn der Produktionsstandort Deutschland hat entscheidende Vorteile: Die Wege zu unseren Zulieferern und zu unseren Kunden sind besonders kurz und Fachkräfte bestens qualifiziert. An den dreizehn Fertigungsinseln wechseln sich unsere Mitarbeitenden, die sämtliche Produktionsprozesse beherrschen, täglich ab. Für die auftragsbezogene Fertigung beziehen wir die erforderlichen Komponenten just in time aus dem Girsberger Werk in Bützberg oder von anderen Zulieferern im näheren Umkreis. Die Kombination aus industrieller Fertigung und Manufaktur ermöglicht sowohl hohe Stückzahlen wie auch, dank der hauseigenen Polsterei, ganz individuelle Lösungen. Einige der Drehstühle liefern wir in einer Variantenvielfalt von bis 200'000 Ausführungen.

Tailored production

We have been making office chairs for half a century in Endingen am Kaiserstuhl. And with good reason, as Germany has some key advantages as a production location – we are close to both our suppliers and customers, and our workforce is highly skilled. Our production employees, who are all experts in every part of the process, alternate daily between the thirteen different stages. For commission-based production, we bring in the necessary components just in time from the Girsberger facility in Bützberg, or from other suppliers nearby. The combination of industrial production and handicraft facilitates both large unit numbers and, thanks to our in-house upholstery shop, we are able to provide fully tailored solutions.

We supply some of our swivel chairs in up to 200,000 different variants.

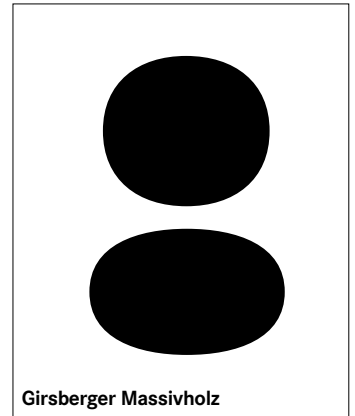
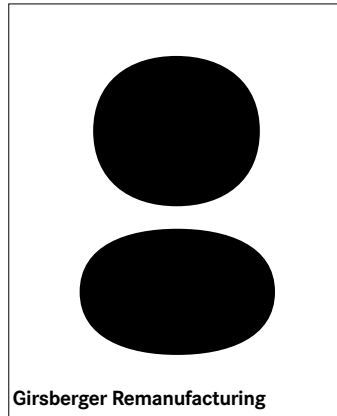
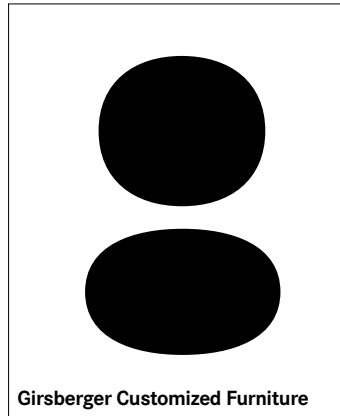
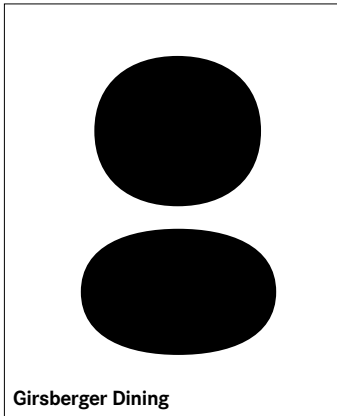

Der Tisch ist der Mittelpunkt des Hauses, am Tisch treffen sich Familie, Freunde und Gäste. Für diesen zentralen Wohnbereich bietet Girsberger Dining eine aussergewöhnliche Kollektion. Sie umfasst Tische, Stühle, Bänke und Sideboards – klar in der Form, intelligent in den Funktionen, sinnlich in den Materialien.

A table is the focal point of a house, where family, friends and guests come together. For this central area of the home, Girsberger Dining offers an outstanding collection. It includes tables, chairs, benches and sideboards – clear in form, intelligent in function, appealing in materials.



Girsberger Customized Furniture realisiert komplette Sitz- und Tischlandschaften nach individuellen Vorstellungen oder Entwürfen von Architekten, Innenarchitekten und Planern. Ob Empfangsbereiche, Lounges, Büros und Konferenzräume oder Restaurants, Bars und Kantinen: Mit seiner Kompetenz für Stuhl und Tisch ist Girsberger ein erfahrener Partner für die Realisierung massgeschneiderter Ausstattungen.

Girsberger Customized Furniture creates complete seating and dining concepts to individual ideas or the designs of architects, interior designers and planners. Be it reception areas, lounges, offices or conference rooms, restaurants or bars and canteens – with our expertise in producing tables and chairs, Girsberger is an experienced partner for creating custom furnishings.



Abgenützte Möbel müssen nicht zwingend ersetzt werden. In vielen Fällen lohnt es sich, sie zu überholen oder zu sanieren. Unsere Spezialisten stellen mit handwerklichem Know-how und modernster Servicetechnologie Funktionen und gepflegtes Aussehen wieder her und sichern damit erneut Wertbeständigkeit.

Worn furniture does not necessarily have to be replaced. In many cases, it is worth repairing or restoring. Using expert craftsmanship and leading-edge service technology, our specialists restore functionality and appearance, thus ensuring that the furniture is able to retain its value.



Seit vielen Jahren verarbeitet Girsberger in Bützberg wertvolles Massivholz. Im Laufe der Zeit begannen wir selbst ein umfangreiches Schnittholzlager aufzubauen und europaweit nach erstklassigen Stämmen zu suchen. Der Eigenbedarf ist mittlerweile von untergeordneter Bedeutung: Der gesamte Bestand von 3500 Kubikmetern luft- und kammergetrocknetem Holz steht für Schreinerbetriebe zur Auswahl bereit.

Girsberger has been manufacturing solid wood in Bützberg for many years. Over time, we started building up our own extensive timber stock and seeking out the best quality tree trunks from across Europe. The company's own requirements have since become secondary and the entire 3,500 cubic metre stock of air-dried and kiln-dried wood is available for carpentry businesses.

Girsberger AG, Bützberg, CH
Girsberger GmbH, Wien, A
Girsberger France, Paris, F
Girsberger GmbH, Endingen, D
Girsberger Benelux BV, Amsterdam, NL
Tuna Girsberger Tic. AS, Silivri, TR

mail@girsberger.com
www.girsberger.com



Impressum / Imprint

Herausgeber: Girsberger Holding AG / Gestaltung: Michael Schade / Fotografie: André Bolliger, Eugen Leu & Partner, Patrick Rohner / Produktion: click it AG, Seon
Für die Unterstützung Dank an: Bildungszentrum Langenthal, 3M EMEA GmbH, Greutmann Bolzern Designstudio, Ribag Licht AG, Hero Schweiz, Ruckstuhl AG, PostFinance AG, Kultur- und Begegnungshaus Schlössli Wohlen, Park innovAARE AG, MinusSan AG
Publisher: Girsberger Holding AG / Design: Michael Schade / Photography: André Bolliger, Eugen Leu & Partner, Patrick Rohner / Production: click it AG, Seon
For their support we thank: Bildungszentrum Langenthal, 3M EMEA GmbH, Greutmann Bolzern Designstudio, Ribag Licht AG, Hero Schweiz, Ruckstuhl AG, PostFinance AG, Kultur- und Begegnungshaus Schlössli Wohlen, Park innovAARE AG, MinusSan AG

